

TYPE	OUTPUT		POLE	TIME RATING	VOLTAGE V	Hz	SYN. SPEED R. P. M
	HP.	kW.					
AFHH			6	CONT.			

TOTALLY ENCLOSED FAN-COOLED TYPE. SQUIRREL-CAGE ROTOR

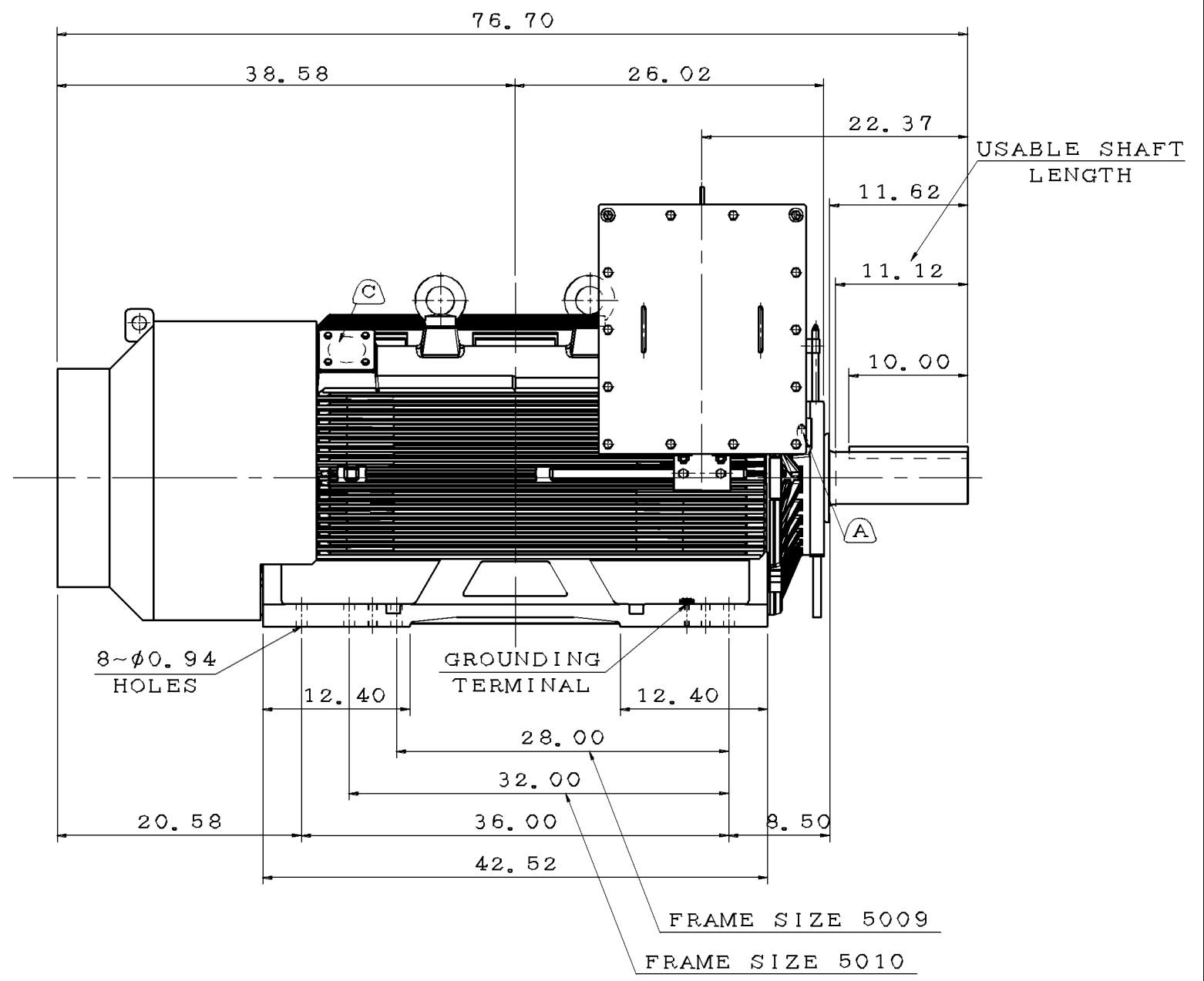
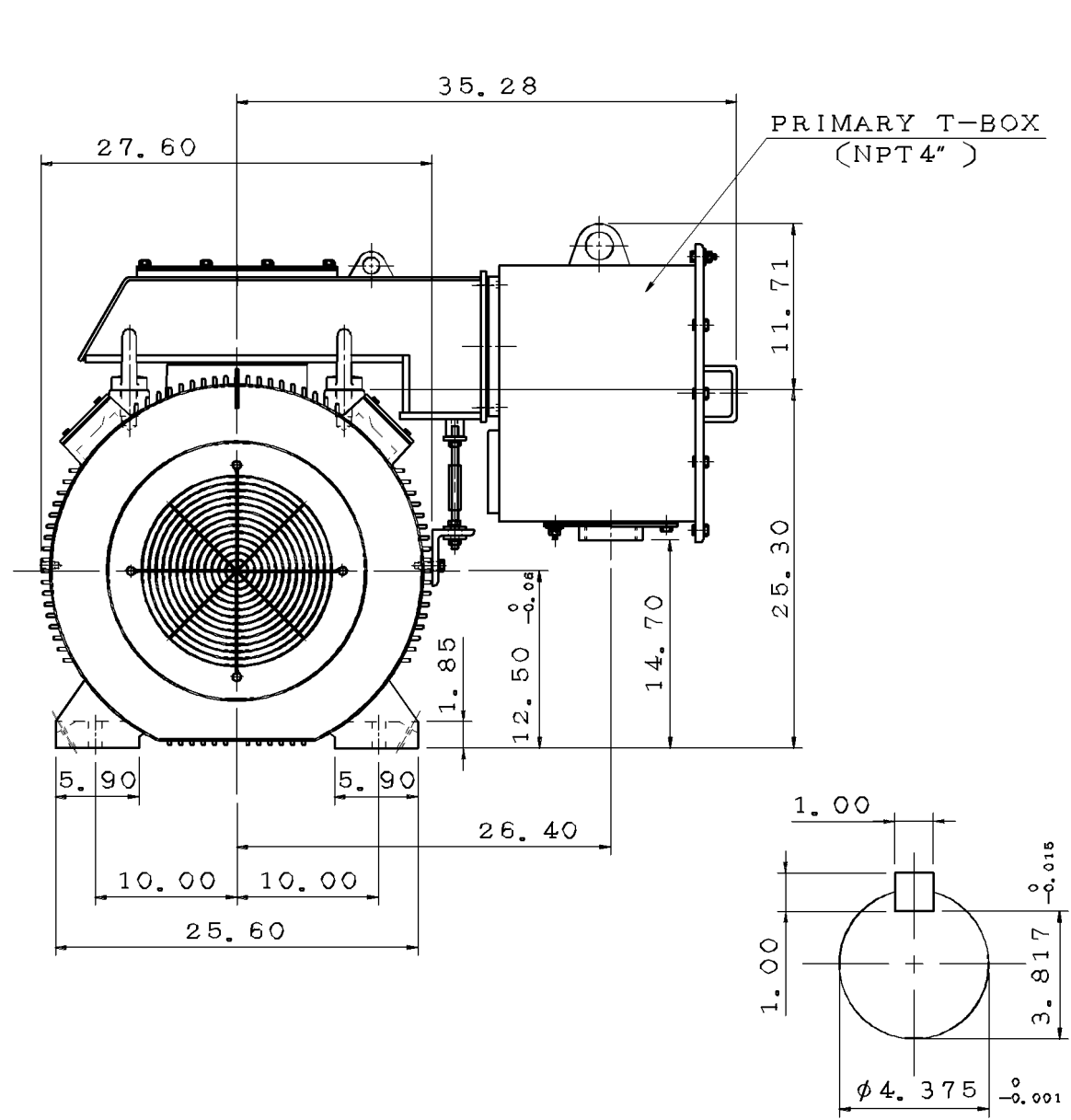

- NOTE:
1. DIMENSIONS IN inch
 2. FRAME NO. 5011C
 3. F CLASS INSULATION
 4. FOR BELT DRIVE
 5. ENCLOSURE: IP55
 6. BEARING SIZE: DRIVE-END NU324C3
OPP. DRIVE-END 6320C3
 7. MOTOR APPROX. WEIGHT: 5320 lb

(B) FOR BEARING RTD, END BRACKETS SHALL BE PRE-DRILLED AND PLUGGED.
 (C) FOR AUXILIARY, FRAME SHALL BE PRE-DRILLED AND COVERD WITH STEEL PLATE.

DWN.	L. JHENG	APR. 22. 2019
CHKD.	H. WANG	APR. 23. 2019
APPD.	C. WANG	APR. 23. 2019

DATE	OUTLINE DIMENSIONS
	3-PHASE INDUCTION MOTOR
TECO Westinghouse	
DWG NO.	REV:01
5A040C170	